

NEGATIVE RAKE SCRAPER

The Negative Rake Scraper is equally at home on all types of wood, although it was designed for use on hardwoods where it can be difficult to achieve a good finish using a regular gouge or scraper. The success of this tool can be attributed to the negative bevel on the top face which stops the wood from riding over the cutting edge and tearing the grain. This, in conjunction with the positive bevel rubbing behind the cutting edge, gives a perfect smooth finish. Works equally well on spindle work, platters and open curve bowls.

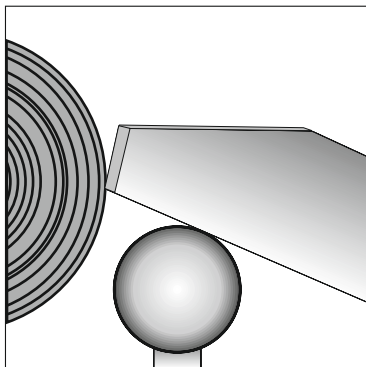

Place the tool rest just below centre and close to the workpiece.

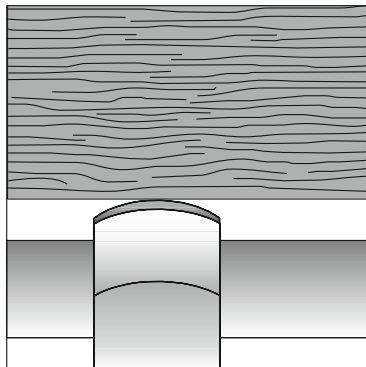

Approach the workpiece with the tool so that the heel of the bevel makes first contact.

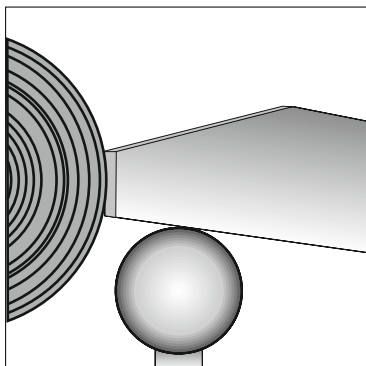

Now raise the handle until the bevel is rubbing and the cutting edge is in contact with the wood.

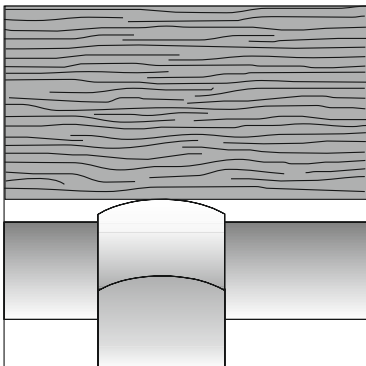

As soon as fine shavings start to appear over the cutting edge stop lifting the handle.

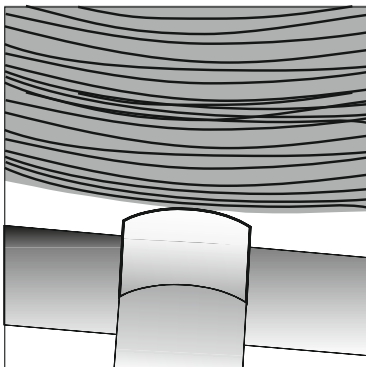

The scraper works equally well on platters and open curve bowls.

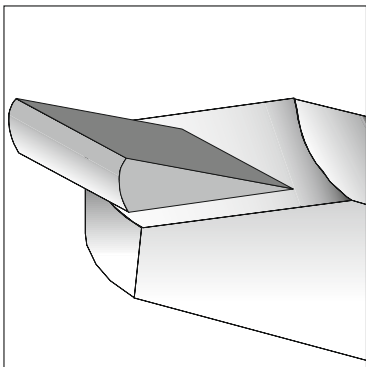

Sharpen across the the top face with a fine honing stone or diamond file.

Introducing another specialist woodturning tool from Robert Sorby

The Stebcentre

Every woodturner's dream drive centre. Suitable for the novice as well as being the perfect drive for the professional. It has serrated teeth and a spring loaded stainless steel centre pin, both of which are unique to the Robert Sorby Stebcentre.



Available sizes:

1/2"	x	1MT	1/2"	x	2MT
7/8"	x	1MT	7/8"	x	2MT
1 1/4"	x	1MT	1 1/4"	x	2MT

For more information on this or any other Robert Sorby product please ask at your nearest dealer or contact:

Robert Sorby

ATHOL ROAD, SHEFFIELD S8 0PA, ENGLAND

Tel: 0114 225 0700 FAX: 0114 225 0710

E-MAIL: sales@robert-sorby.co.uk Website: www.robert-sorby.co.uk

Robert Sorby Ltd, Registered in England: Company No 3464018

Registered office: Atlas Way, Atlas North, Sheffield, S4 7QQ

VAT No GB 172 4019 84